

**MOTOR SPECIFICATION SHEET**

MODEL : SF-QR 1/2HP 2P (LT)

USED FOR : STANDARD

DESCRIPTION	DETAIL			
PHASE	3			
MODEL NAME	SF-QR			
RATED OUTPUT, HP (kW)	1/2 (0.4)			
POLE	2			
CODE	MEATH CODE : 1M002F-200040QRGD0			
OUTLINE DRAWING NO.	ONM74O173-C			
RATED VOLTAGE (V)	220	380	415	
RATED FREQUENCY (Hz)	50	50	50	
RATED CURRENT (A)	1.80	1.05	1.00	
RATED SPEED (min <sup>-1</sup> )	2830	2830	2860	
RATED EFFICIENCY (%)	70.7	70.7	73.6	
EFFICIENCY CLASS	IE1			
THERMAL CLASS	155(F)			
RATING	S1 (CONTINUOUS)			
ENCLOSURE CONSTRUCTION	TOTALLY ENCLOSED FAN COOLED			
DEGREES OF PROTECTION	IP55			
METHOD OF COOLING	IC411			
FRAME NO.	71M			
WEIGHT (kg)	7			
STANDARD	IEC 60034-1, IEC 60034-30-1			
INSTALLATION	FOOT MOUNTED			
ROTATION	CCW (VIEWED FROM SHAFT END)			
BEARING	LOAD SIDE : 6202ZZ			
	OPPOSITE SIDE : 6201ZZ			
BEARING GREASE	UREA GREASE			
NOISE (dB.A)	69			
VIBRATION	V15			
CIRCUMSTANCE CONDITION	AMBIENT TEMPERATURE : -20 ~ +40°C			
	AMBIENT HUMIDITY : 95%RH OR LESS			
	ABOVE SEA LEVEL : 1000m OR LESS			
	ENVIRONMENT : NO BURSTING/EROSIVE GAS OR VAPOR			
COLOR	MUNSELL N1.5 (BLACK)			
TERMINAL BOX	NO. OF LEAD WIRES : 6			
	SOURCE CONNECTION : TERMINAL BLOCK			
SHAFT SWING	≤0.03mm			
MATERIAL	FRAME : STEEL PLATE			
	BRACKET : STEEL PLATE			
	SHAFT : CARBON STEEL			
	STATOR CORE : ELECTRICAL STEEL			
	WIRE : ENAMELLED COPPER MAGNET WIRE			
	ROTOR CORE : ELECTRICAL STEEL			
	CONDUCTOR : ALUMINIUM			
	TERMINAL BOX : STEEL PLATE			
PAINTING : POLYURETHANE RESIN				
PRODUCTION COUNTRY	THAILAND			

Specifications subject to change without notice.

<b>SPECIFICATION SHEET NO.</b>				
SS-M-7985-A				

MODEL SF-QR THREE PHASE INDUCTION MOTOR OUTLINE DRAWING

TOTALLY ENCLOSED FAN COOLED TYPE  
 DEGREES OF PROTECTION IP55  
 DUST & WATER JET PROOF

CUSTOMER \_\_\_\_\_  
 USER \_\_\_\_\_  
 FOR \_\_\_\_\_  
 CUSTOMER'S ORDER NO. \_\_\_\_\_  
 QUANTITY \_\_\_\_\_  
 MFG. ORDER NO. \_\_\_\_\_

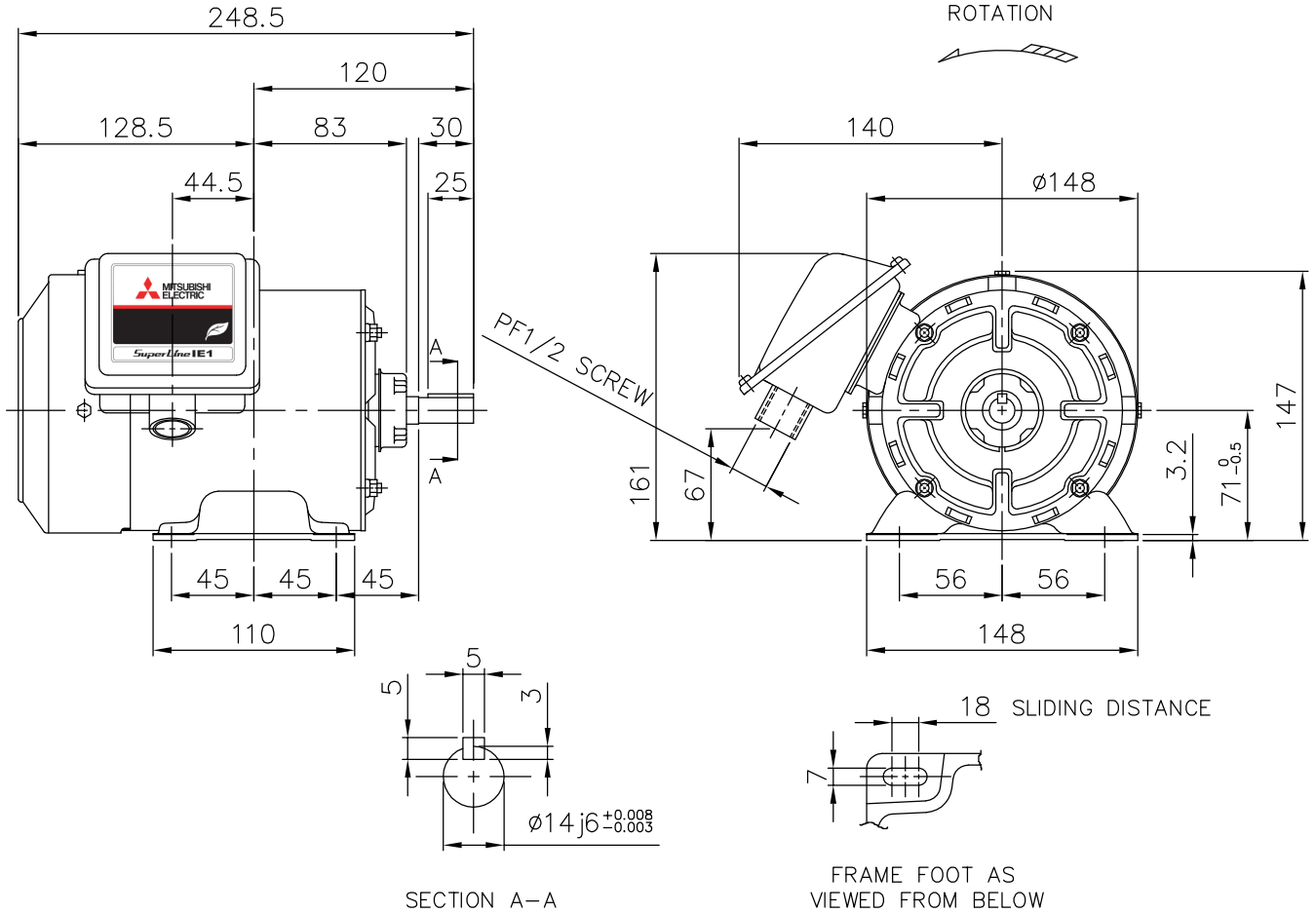

YOUR ORDER	FRAME SIZE	RATING	TH. CLASS	AMB. TEMP.	BEARINGS		COLOR	DIRECTION OF ROTATION (VIEWED FROM SHAFT END)	NO. OF LEAD WIRES	REMARKS
					LOAD SIDE	OPP. SIDE				
	71M	S1 (CONT.)	155(F)	40°C	6202ZZ	6201ZZ	BLACK (MUNSELL N1.5)	CCW	6	

YOUR ORDER	OUTPUT		POLES	VOLT	HERTZ	AMP.	RPM	IE CODE-RATED EFF.	REMARKS
	HP	kW							
	1/2	0.4	2	220/380/415	50	1.80/1.05/1.00	2830/2830/2860	IE1 70.7/70.7%/73.6%	LT
	1/2	0.4	4	220/380/415	50	2.00/1.14/1.18	1400/1400/1420	IE1 73.3%/73.3%/72.0%	LT
	1/4	0.2	6	220/380/415	50	1.23/0.71/0.74	920/920/930	IE1 64.5%/64.5%/63.5%	LT

MITSUBISHI ELECTRIC AUTOMATION (THAILAND) CO., LTD.

		OUTLINE DRAWING NO.	REV.
	DIMENSION IN mm.	0 N M 7 4 0 1 7 3	C
SCALE : NTS			